

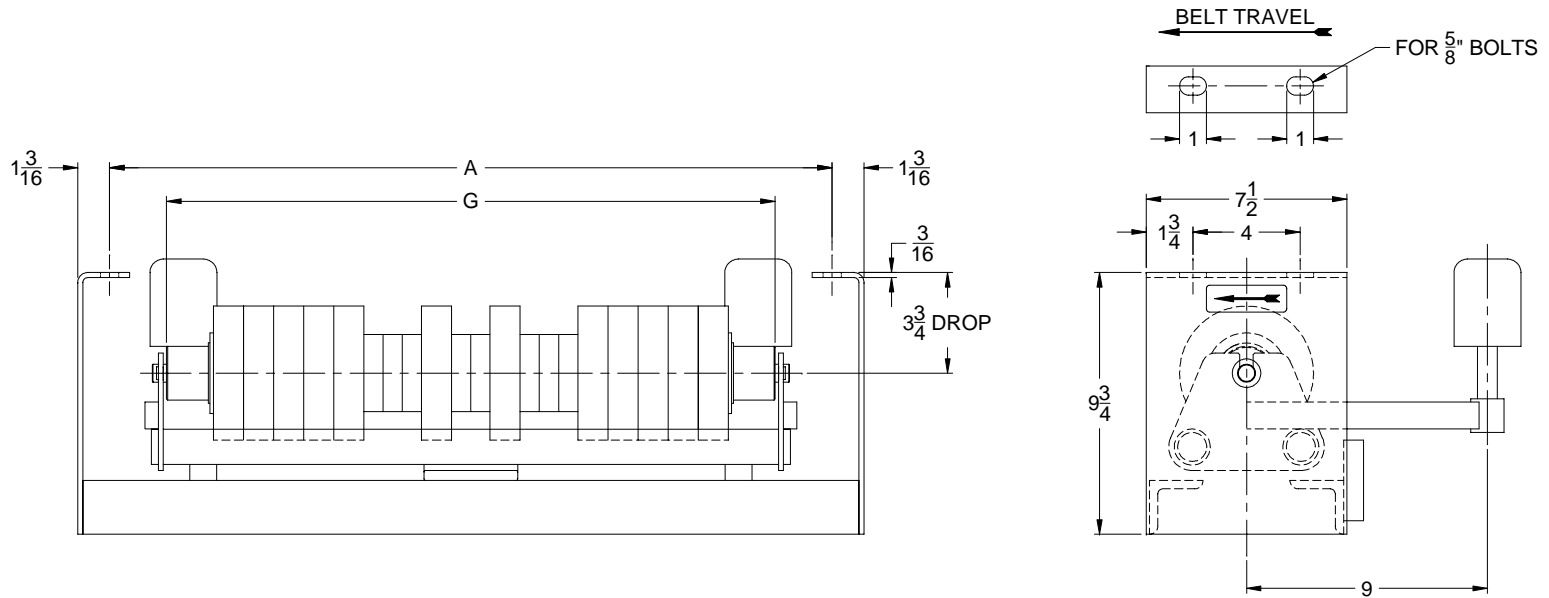

STEPHENS-ADAMSON CONVEYING

Note: Dimensions for REFERENCE ONLY and are SUBJECT TO CHANGE WITHOUT NOTICE.
Contact Stephens-Adamson Conveying for Certified Dimensions Prints.

CEMA "B" 2170 Series ST-PA Rubber Disc Return Idlers - Sealed for Life



'Dimensions in Inches'

Belt Width	Assembly Part Number	R710-2175-3-3/4-ST-PA Return Idler Dimensions 5" dia. Rolls		Weight
		A	G	
18"	205-18-45-0120	27	22-3/4	75 lbs.
20"	205-20-45-0120	29	24-3/4	78 lbs.
24"	205-24-45-0120	33	28-3/4	84 lbs.
30"	205-30-45-0120	39	34-3/4	95 lbs.
36"	205-36-45-0120	45	40-3/4	105 lbs.
42"	205-42-45-0120	51	46-3/4	118 lbs.
48"	205-48-45-0120	57	52-3/4	130 lbs.

STEPHENS-ADAMSON CONVEYING

www.Stephens-Adamson.com

CANADA
Telephone: 1-800-510-3802
Fax: 1-613-967-8128

U.S.A.
Telephone: 1-800-638-6788
Fax: 1-800-866-1438

INTERNATIONAL
Telephone: 1-613-962-3411
Fax: 1-613-967-8128

DS-E-IDL-00-045 A



STEPHENS-ADAMSON CONVEYING

Note: Dimensions for REFERENCE ONLY and are SUBJECT TO CHANGE WITHOUT NOTICE.
Contact Stephens-Adamson Conveying for Certified Dimensions Prints.

CEMA "B" 2170 Series ST-PA Rubber Disc Return Idlers - Sealed for Life

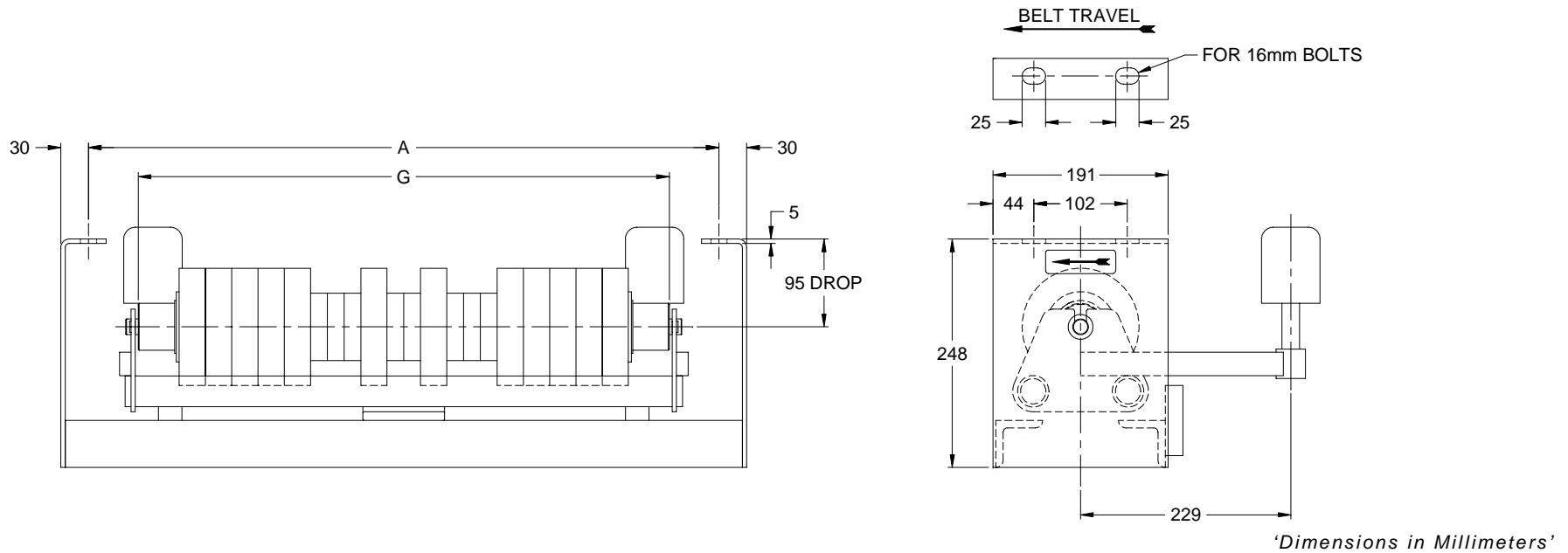

Belt Width	Assembly Part Number	R710-2175-3-3/4-ST-PA Return Idler Dimensions 127 mm dia. Rolls		Assembly Weight
		A	G	
457 mm	205-18-45-0120	686	578	30 kg.
508 mm	205-20-45-0120	737	629	32 kg.
610 mm	205-24-45-0120	838	730	34 kg.
762 mm	205-30-45-0120	991	883	39 kg.
914 mm	205-36-45-0120	1143	1035	43 kg.
1067 mm	205-42-45-0120	1295	1187	49 kg.
1219 mm	205-48-45-0120	1448	1340	54 kg.

STEPHENS-ADAMSON CONVEYING

www.Stephens-Adamson.com

CANADA
Telephone: 1-800-510-3802
Fax: 1-613-967-8128

U.S.A.
Telephone: 1-800-638-6788
Fax: 1-800-866-1438

INTERNATIONAL
Telephone: 1-613-962-3411
Fax: 1-613-967-8128

DS-E-IDL-00-045 A